

TWT Series

Worktop Refrigerators/Freezers



Both durable and compact, the TWT Series of worktop refrigerators and freezers keep refrigerated or frozen ingredients right where you need them in prep or server's areas. An enhanced cold air circulation system, coupled with a high quality stainless steel interior and exterior makes the TWT Series the best worktop refrigerators and freezers on the market.

- 3½" backsplash
- High quality stainless steel interior & exterior
- Foamed-in-place high density polyurethane cell insulation
- Self closing swing doors
- ETL Safety & Sanitation Approved





Features

- 3.5" backsplash
- 304 series stainless steel interior
- 430 series stainless steel exterior
- Recessed handles
- 3 plastic coated steel shelves included
- Foamed in place polyurethane insulation
- Removable door gasket for easy cleaning
- Self closing door
- Automatic defrosting
- 4 casters - 2 locking
- ETL Sanitation Listed

Technical Data

Dimensions

Exterior Dimensions (W x D x H)	71" x 30" x 35.25"
Interior Dimensions (W x D x H)	67" x 22.75" x 23.5"
Net Volume (cu. ft.)	20.9 cu. ft.
Net Weight	359.35 lbs.
Packaging Dimensions (W x D x H)	74.25" x 32.25" x 38.25"

Cooling

Temperature Range	32° - 41° F
Refrigerant	R134a
Maximum Ambient Temperature Rating	90° F
Defrosting	Automatic
Temperature Display	No
Temperature Controller	Mechanical
Horsepower	1/2

Construction

Exterior Material	430 series stainless steel
Interior Material	304 Series Stainless Steel
Insulation Material	Foamed in Place Polyurethane
Shelf Material	Plastic Coated Steel
Shelf Load Capacity	88 lbs.

Electrical

Voltage	120
Amps	9
Hz	60
Phase	1
Electrical Cord Length	84"

Keep your chilled ingredients fresh, crisp, and nearby as you work with the Avantco TWT-72R 72" triple door worktop refrigerator! This refrigerator features a 71" x 30" work surface to give you plenty of room to work, while the 3 1/2" backsplash protects your walls from stains and food acids. Ideal for snack bars, concession stands, pizzerias, sandwich shops, and even break rooms, this unit has 20.9 cu. ft. of storage space and comes mounted on casters (2 locking) so you can easily roll it out for cleaning or routine maintenance.

A corrosion-resistant 304 stainless steel interior also makes it easy to clean and ensures you'll never be set back by spills, while three adjustable plastic coated steel shelves let you adapt to changing menu needs. Three self-closing doors minimize temperatures loss by preventing the doors from being left open after retrieving items from inside the refrigerator.

For reliable cooling, this refrigerator circulates R134A refrigerant to maintain temperatures between 32 and 41 degrees Fahrenheit. The rear and side-breathing refrigeration system is centered around a 1/2 hp compressor and foamed-in place polyurethane insulation to ensure efficient operation, and a top mounted cooling fan ensures even temperatures throughout the interior. Plus, a simple digital readout on the front displays the temperature at all times.

Plan View

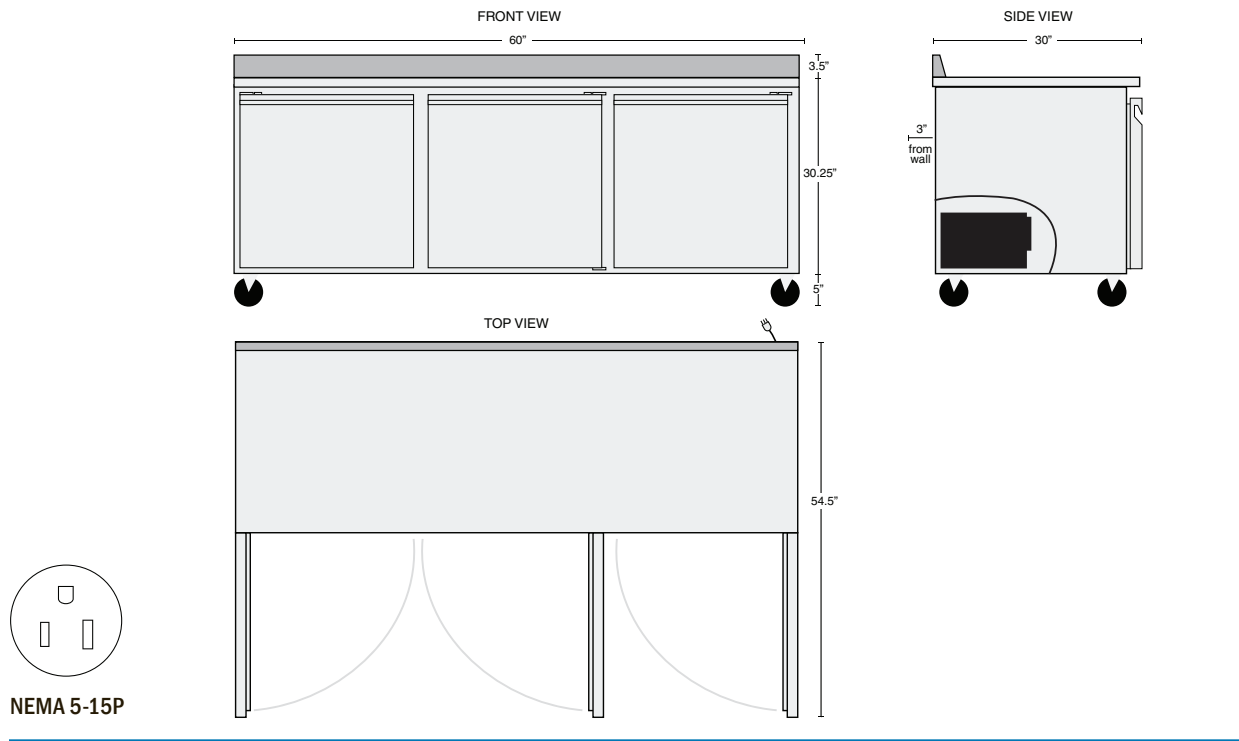



1 year
WARRANTY



5 year
WARRANTY

Parts & Labor Compressor

All Avantco Refrigerators and Freezers are backed by a 1 year parts and labor warranty, with a 5 year warranty on the compressor. For warranty inquiries or service, first locate the serial number plate on the front of the unit, or inside the door jamb. Next, call 1-800-678-5517. Be sure to have the serial and model numbers available when contacting service technicians.