

# CFD Series

## Reach In Refrigerators / Freezers

The CFD Series of commercial upright refrigerators and freezers brings high performance and quality to your kitchen. Designed to be functional and efficient, the CFD Series provides the best value in commercial refrigeration.



- High quality stainless steel interior & exterior
- ETL safety & sanitation approved
- Digital temperature control w/LCD display
- Outstanding temperature preservation & reduced energy consumption

REFRIGERATION  
**AVANTCO**



With its durable, 430 series stainless steel exterior and 304 series stainless steel interior, the triple door reach in refrigerator is strong enough to stand up to the daily demands of your busy restaurant kitchen.

The 3 door reach in refrigerator features self closing doors and six casters, two of which are locking, which make it easy to move the reach in refrigerator for cleaning and servicing. Digital controls and an LCD readout make it easy to adjust the interior temperature.

Nine plastic coated wire shelves are included. Adjustable mounting brackets allow you to easily change the shelving configuration, to accommodate larger inventory supplies, or small, prepared garnishes, ingredients, and even desserts. The mounting brackets are spaced wide enough to hold full size food pans as well.

The reach in refrigerator's bottom mounted, 1/2 hp compressor uses R134a refrigerant and is easily accessible for cleaning and maintenance. Foamed in place polyurethane cell insulation helps maintain interior temperatures. The reach in refrigerator has a temperature range of 32° to 50° Fahrenheit.

The triple door reach in refrigerator has a 120V, 9.9 amp, 60 Hz. electrical rating, and is ETL Sanitation Listed and NSF Compliant.

### Features

- 304 series stainless steel interior
- 430 series stainless steel exterior
- Self closing doors
- Recessed door handles
- 9 plastic coated steel shelves included
- Digital temperature controls
- with LCD Display
- Automatic defrosting
- 6 casters (two locking)
- Door lock
- Foamed in place polyurethane insulation
- ETL Sanitation Listed

### Technical Data

#### Dimensions

Exterior Dimensions (W x D x H)	81" x 32" x 82.5"
Interior Dimensions (W x D x H)	76.25" x 27" x 60.25"
Net Volume (cu. ft.)	72 cu. ft.
Net Weight	753 lbs
Packaging Dimensions (W x D x H)	

#### Cooling

Temperature Range	32° - 50° F
Refrigerant	R134a
Maximum Ambient Temperature Rating	100.4° F
Defrosting	Automatic
Temperature Display	Yes
Temperature Controller	Digital
H/P	1/2

#### Construction

Exterior Material	430 series stainless steel
Interior Material	304 series stainless steel
Insulation Material	Foamed in place polyurethane
Shelf Material	Plastic coated steel
Shelf Load Capacity	120 lbs

#### Electrical

Voltage	120
Amps	9.9
Hz	60
Phase	1

## Plan View

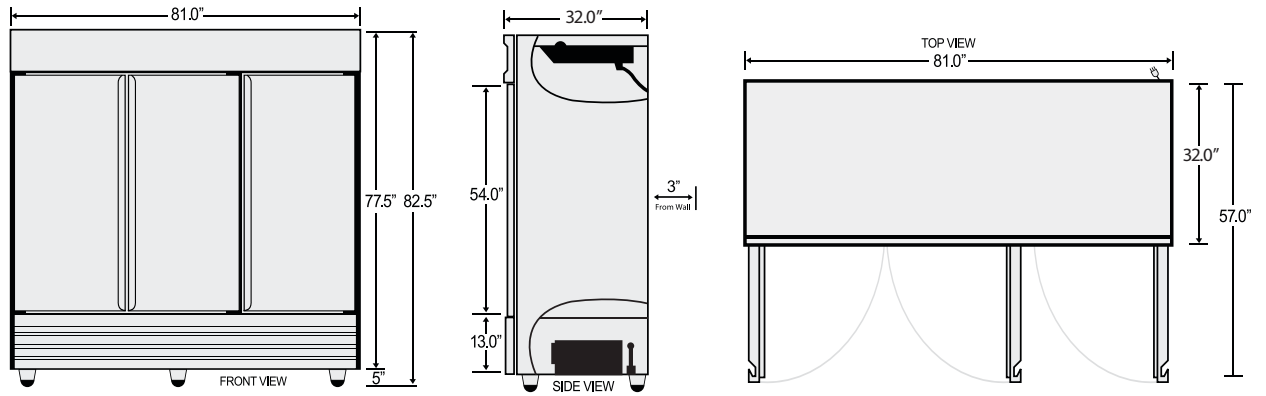

Parts & Labor



Compressor

All Avantco Refrigerators and Freezers are backed by a 5 year warranty on the compressor, and a 1 year parts and labor warranty.